

# ML-SL-SQ Series



## SQUARE Twin Heads Motion Sensor Security Fixture

Project Name:	Order Number:	Prepare by:	Note:	Date:	Type:

### SQUARE TWIN HEADS

The **MW-SL-SQ** square twin head security light increases safety and security for the area by illuminating dark exterior areas. It comes with a automate motion and photocell sensor. Light can be turned on automatic at night when the motion sensor pickup any movement within the detect range. Also, the dusk-to-dawn technology allowing the light to be turned ON at night and turned OFF in the morning when it has been put into Dusk to Dawn mode. The **MW-SL-SQ** security light is Energy Star® and UL certified. It's designed to be robust and long lasting, the die-casting aluminum housing protects the light against extreme weather. It satisfies most application needs in landscaping, side walk, parking lots, public area and other outdoor usage.



### DIMENSION

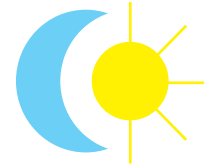
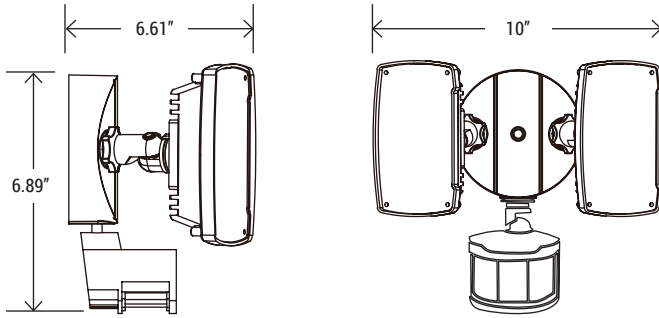

### Dusk-To-Dawn

The dusk-to-dawn technology allowing the light to be turned ON at night and turned OFF in the morning.

*Energy Star® and ETL certified. It can be used to comply with Title-24 and JA8 high efficacy light source requirements.*

### TECHNICAL SUMMARY

MODEL #	LUMENS	WATTS	EFFICACY	CRI	VOLTAGE	DETECTION	CCT	PF	LIFE	OPERATING TEMP.
<b>ML-SL-SQ-WH-50K</b>	<b>1400</b>	<b>20W</b>	<b>70 lm/W</b>	<b>90</b>	<b>120V-277V 60 Hz</b>	<b>up to 10ft</b>	<b>5000K</b>	<b>&gt;0.9</b>	<b>50,000 hrs</b>	<b>-5°F ~ 104°F</b>
<b>ML-SL-SQ-BZ-50K</b>										

### PART NUMBER ORDERING SUMMARY

**ML - SL - SQ - WH - 50K**

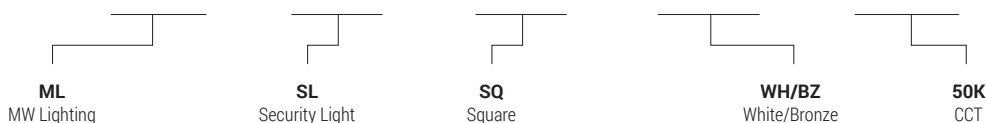

# ML-SL-SQ Series



## SQUARE Twin Heads Motion Sensor Security Fixture

Project Name:	Order Number:	Prepare by:	Note:	Date:	Type:

### ADJUSTABLE MOTION & PHOTOCELL SENSOR

- Motion detect sensitivity adjustable
- Lighting time adjustable
- Automate dusk-to-dawn functionality

### CONSTRUCTION

- Unit includes die-cast aluminum housing, LED array, heat sink, lens, foam gasket and adjustable motion sensor
- High quality PC lens
- Efficiency LED array
- Diffuse for uniform illumination

### DRIVER

- High efficiency integral 120V-277V 60Hz universal input voltage

### MOUNTING

- Pre-wired motion sensor
- Wiring nuts and fasten included

### LISTING

UL Listed, Energy Star Listed, Suitable for Damp Locations, Title 24 JA8-2022, RoHS

### WARRANTY

5 years manufacturer warranty, consult factory for more details. Terms and conditions may apply.

### AVAILABLE COLORS



**ML-SL-SQ-WH-50K**  
In White



**ML-SL-SQ-BZ-50K**  
In Bronze

### PHOTOMETRY

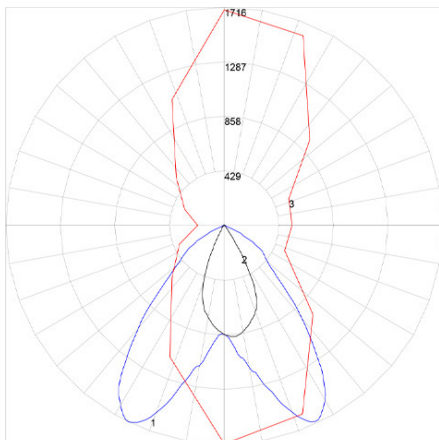

Maximum Candela = 1716.42 Located At Horizontal Angle = 270, Vertical Angle = 26  
 # 1 - Vertical Plane Through Horizontal Angles (270 - 90) (Through Max. Cd.)  
 # 2 - Vertical Plane Through Horizontal Angles (0 - 180)  
 # 3 - Horizontal Cone Through Vertical Angle (26) (Through Max. Cd.)