

# LED emergency driver

## STB45FA Series

0...10V Dimming  
Drive lamp's driver



STB45F A-08WLi-170

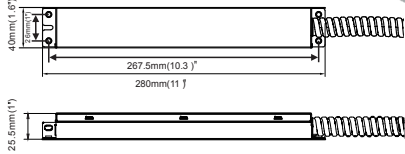

STB45F A-18WLi-170

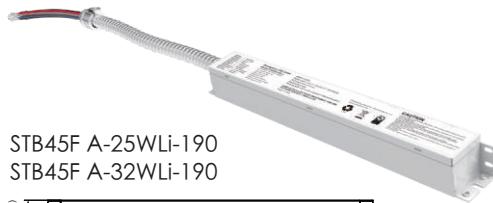
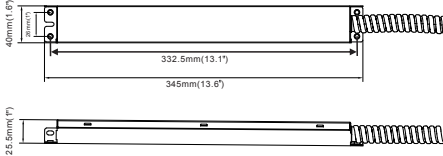

STB45F A-25WLi-190  
STB45F A-32WLi-190

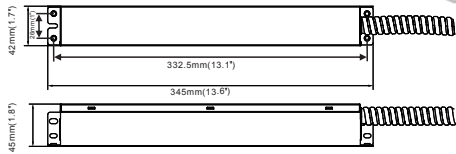

### Applications

- UL Listed for damp locations.
- Suit for 10-300W lamp with 0-10v dimming function.
- Suit for 10-32W below lamp with or without 0-10v dimming function.
- DC120-190V Output.
- Initial functional self-check.
- Built-in high power AC relay to control normal led driver operation.
- Used with Lithium iron battery.
- Over-charging/discharging protection
- Rest mode
- >90 minutes emergency time.
- Ta:5..50 °C (41°F..122°F)
- Initial functional self-check
- IP20



### Initial functional self-check

Emergency pack will make a initial functional self-check automatically and red light slow flash. Checking points as below:

- Compatibility with lamp
- Lamp starting current
- Lamp starting time
- Dimming starting voltage
- Dimming slope

After passing the test, emergency pack goes to operate normally and red light stable.

It will never start this test again afterward, unless it goes into rest mode or battery is disconnected.

### Protections:

- Input over current protection.
- Output over voltage protection.
- Output under current protection.
- Output short circuit protection.

### Ordering data

Model No.:	Rated Input	Rated Output	Battery pack	Dimension(L*W*H)	Emergency time
STB45FA-08WLi-170	100-277Vac,50/60Hz	DC150-170V 8W	Li-ion	280×40×25.5mm	>90minutes
STB45FA-18WLi-170	100-277Vac,50/60Hz	DC150-170V 18W	Li-ion	345×40×25.5mm	>90minutes
STB45FA-25WLi-190	100-277Vac,50/60Hz	DC120-190V 25W	Li-ion	345×42×45mm	>90minutes
STB45FA-32WLi-190	100-277Vac,50/60Hz	DC120-190V 32W	Li-ion	345×42×45mm	>90minutes

## Technical data

Item	STB45FA-08WLi-170	STB45FA-18WLi-170	STB45FA-25WLi-190	STB45FA-32WLi-190
Rated input	100-277Vac, 50/60Hz, 5W max	100-277Vac, 50/60Hz, 5W max	100-277Vac, 50/60Hz, 8W max	100-277Vac, 0/60Hz, 8W max
Input current	120mA max	120mA max	150mA max	150mA max
Power factor	>0.5	>0.5	>0.5	>0.5
Lin to Lout(Normal driver input)	AC 3A max	AC 3A max	AC 3A max	AC 3A max
Battery pack voltage/capacity	Li-ion, 7.4V 2.6Ah, 19.2Wh	Li-ion, 14.8 V2.6Ah, 38.48Wh	Li-ion, 11.1V 5.2Ah, 57.72Wh	Li-ion, 14.8V 5.2Ah, 76.96Wh
Output voltage(E.M mode)	DC150-170V, 8W	DC150-170V, 18W	DC120-190V, 25W	DC120-190V, 32W
Output power(E.M mode)	8W	18W	25W	32W
Startup capability/time	15W 500ms	36W 500ms	400W 500ms	400W 500ms
Recharge time	≥24hours	≥24hours	≥36hours	≥36hours
Ta	5...50 C (41°F...122°F)	5...50 C (41°F...122°F)	5...50 C (41°F...122°F)	5...50 C (41°F...122°F)
Suitable lamp power	6-80W	10-150W	10-250W	10-300W
Lamp power that must be with 0-10V or 1-10V dimmer function	≥8W	≥18W	≥25W	≥32W
Lamp power at 1V dimmer voltage(1W margin power)	≤7W	≤17W	≤24W	≤31W

## Wiring diagram

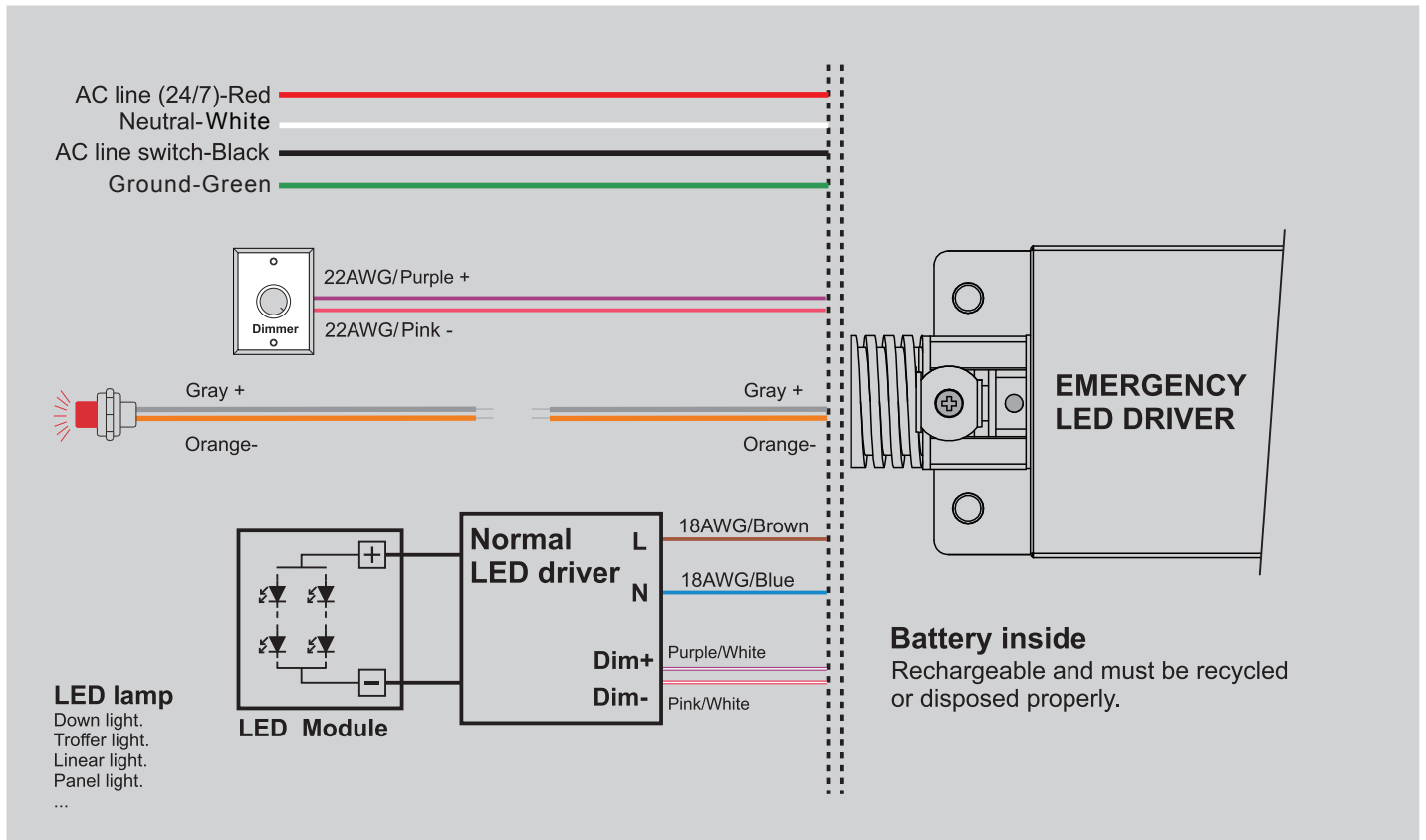

## Test switch and LED indicator

### LED indicator

Red stable: Charging mode  
 Charging Fully  
 OFF: Emergency mode

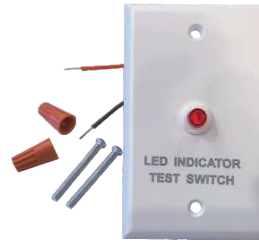

Indicator Light	Status	Comment
Red Stable	Charging Mode, Fully charged	AC mode, unit is operating correctly.
Flashing 2 times, Light off 2s, loop	Battery Error	Battery disconnected or fail 90mins duration test due to insufficient capacity
Flashing 3 times, Light off 2s, loop	Charging Error	Ensure input wiring is correct and verify input voltage & frequency are correct and stable.
Flashing 5 times, Light off 2s, loop	Temp Error	Overtemperature
Continuous Flashing	LED load abnormal	Matching test fail, self-check output abnormality

### Test switch

Press switch to enter into emergency mode, release to recover charging mode

### Rest mode

Rest mode can ensure battery long term storage, leakage current is very low in rest mode.  
 Press and hold the test switch for over 3 seconds in the emergency mode to enter into rest mode.  
 In rest mode, the battery is completely disconnected from the inverter, and the small leakage current can make its storage time longer.

### Cancel faulty mode

End discharge  
 Disconnect battery in emergency mode  
 Press test button over 3 seconds in emergency mode.

## Installation instruction:

- please install this product properly by the licensed electrician.
- please check and confirm all the data and usage surrounding before installation.
- this item could be used in the sealed fixtures or installed open area of the fixtures.
- please keep it away from the flammable materials with a place of good heat dissipation.
- please charge the battery consistently for >24 hours for the first time usage so as to activate the whole battery cells of discharging/charging duration.**

## WARRANTY

This product is warranted for 5 years from the date of purchase. If this product does not perform to the specifications supplied on this package, send an email to [support@runbisonlighting.com](mailto:support@runbisonlighting.com) for product return and replacement. This replacement is the sole remedy available. Liability for incidental or consequential damage is expressly excluded.