

DUAL HEAD HIGH POWER LED EMERGENCY LIGHT

Project Name:	Order Number:	Prepare by:	Note:	Date:	Type:

This **Dual Head High Power LED Emergency Light** is easy to install almost anywhere with an easy-to-connect backplate and dual heads that can rotate 180 degree. It combines quality and reliability with intelligent, because it is made from flame-retardant, impact-resistant thermoplastic and suitable for use in humid environment. It can be used for up to 90 minutes after being 24 hours fully charged.



DIMENSION

Length	13.67"
Width	3.71"
Height	3.43"

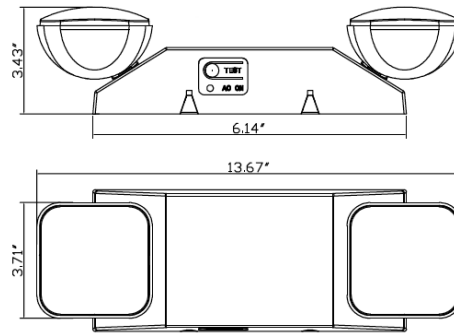

TECHNICAL SUMMARY

MODEL #	NAME	VOLTAGE	COLOR	BATTERY	RECHARGE TIME	EMERGENCY OPERATION	LED CHIPS	WATTAGE	LUMEN	CRI
MJ-1L	Dual Heads Emergency Light	120/277V	N/A	build-in 3.6V	≤24hrs	≥90mins	24	2.4W	150LM	80

ELECTRICAL

- 120/277V voltage operation. Optional multi-tap voltage available.
- Built-in 3.6V 700mAH rechargeable Ni-CD battery for minimum 90 minutes emergency operation
- Maximum 24 hours for full recharge time.
- Test switch and charge indicator.

MOUNTING

- Innovative, easy installation in minutes.
- Universal pattern on back plate for wall mount.

HOUSING

- Injection-molded, engineering grade. 5VA flame retardant.
- High-impact resistant, thermoplastic in white or black finish.

WARRANTY/LISTING

- Two years warranty on all electronics and housing. Battery two years warranty for battery meets UL 924.
- cUL and UL listed for damp location (0°C-40°C).

