

MLWL Series

LED Landscape Well Light

Project Name:	Order Number:	Prepare by:	Note:	Date:	Type:

The MLWL series features a die-cast aluminum lighting body with a frosted PC lens, designed for standard United States junction pipes. Available in black or ORB body finishes, it is suitable for wet locations and ensures easy installation. Operating efficiently on 12-24V AC/DC, it functions within a temperature range of -4°F to 104°F. With a power consumption of 6W, a CRI of >90Ra, and a copper cable material, it delivers 450-520 lumens with a 5CCT color temperature. The fixture has a lifespan of 50,000 hours and utilizes SMD2835 LEDs with a 52° beam angle. Rated IP65, it is ideal for low-voltage landscape lighting applications, including pathways, driveways, decks, and gardens.



MLWL-6W-30K-LVER



DIMENSION

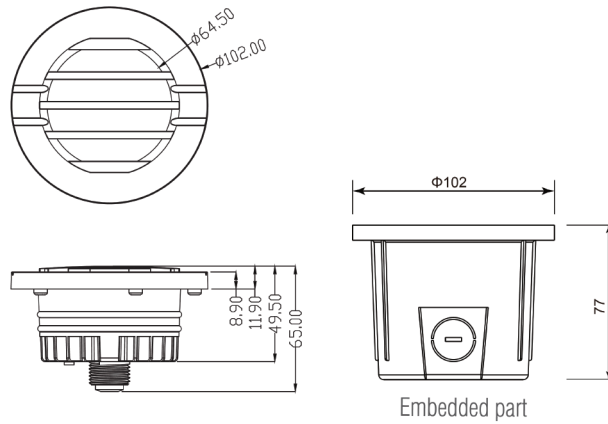

TECHNICAL SUMMARY

MODEL NO.	TOP	WATTS	LUMENS	CCT	VOLTAGE	DIMMING	CRI	CERTIFICATION
MLWL-6W-30K-FLAT	Open Flat Top	6W	520LM	27/30/35/40/50K	12-24V	N/A	N/A	ETL
MLWL-6W-30K-LVER	Louver Top	6W	520LM	27/30/35/40/50K	12-245V	N/A	N/A	ETL
MLWL-6W-30K-SHLD	Shielded Top	6W	520LM	27/30/35/40/50K	12-24V	N/A	N/A	ETL

PART NUMBER ORDERING SUMMARY

MLWL-6W-30K-LVER

Landscape Well Light
MW Lighting

6W
Wattage

30K
CCT

Louver Top
Various Top

LED Landscape Well Light

Project Name:	Order Number:	Prepare by:	Note:	Date:	Type:

CONSTRUCTION

- Unit includes heavy duty metal frame, LED array, heat sink, hanger, security cable and high quality LED tube.

WARRANTY

5 years manufacturer warranty, consult www.mwledlighting.com for more details.

* Terms and conditions may apply.

MOUNTING

-

HIGHLIGHT

Durable Construction

Made from die-cast aluminum, ensuring long-lasting durability and resistance to harsh outdoor conditions.

Easy Installation

Designed for standard U.S. junction pipes, allowing for quick and hassle-free setup.